

Baghouse filter with regeneration by compressed air

G&G - JET BAG 24-16-20-55



order number

filter area

air flow

type of filter media

single element area

type of regeneration

compressed air consumption

number of filter hoses

temperature resistance

waste bin

design for EX

inlet flange

output flange

length - width - height

filter weight

air flow at filtration rate

the fan is not included

JET BAG 24-16-20-55

269 m²

***1 16140m³/h *2 25824m³/h *3 40350 m³/h**

flat filter hose

0,70 m²

JET system

36 Nm³ (6 bar)

384 ks / 384 pcs.

150°C

kbelík 50 litrů / 50 liters bucket

not for explosive dust

2x 1020x570 (mm)

2x750x250 (mm)

2225 / 3360 / 6101 (mm)

3240 kg

***1 16140 m³/h at 1,0 m/min**

***2 25824 m³/h at 1,6 m/min**

***3 40350 m³/h at 2,5 m/min**

Description

Baghouse filter from the production of G&G Filtration is a dry, cloth-type dust filtration device with automatic regeneration of the filtering medium by compressed air. Regeneration of the filter medium is performed cyclically at set time intervals with the possibility of control according to the current pressure loss. The suction power is determined by the fan used according to the type of material and the required load on the filter surface. The fan is not part of the filter unit. Recommended loads on filtering medium for each type of dust are listed below. The filtration equipment is made in an outdoor version without the necessity of roofing. The filtration equipment achieves high filtration efficiency - 99%, so it is possible to return the filtered air mass back to the production hall area. The ratio of air return to the hall space and outdoor environment is determined by the technology designer according to the characteristics of the extracted material and the air conditions of the production object.

Use of baghouse filter

The filtering device is designed for dust separation from exhausted air mass. The filtration system is always composed of a specific filter unit and an associated exhaust fan. The combination of the filter unit and exhaust fans differs for different types of dust and according to the required filter surface. The load on the filter surface varies for the dust types due to: fraction size, density, area, tack, grease and other factors that we transfer to the common unit in industrial filtration, and this is the load on the filter surface. The purpose is to design a filter + fan combination for a specific type of dust extraction and process so that the filtering device achieves continuous extraction performance and filtered air purity over the declared lifetime of the filter medium - at least 20,000 operating hours. The incorrect ratio of the used filtering equipment to the fan results in unstable operating conditions with a characteristic rapid increase of the pressure loss of the filter medium and the degradation of the suction power. Available filter variants: With a discharge to a 55-litre bucket, to a 200-litre container, to the Big-Bag. All types of filters are made for non-explosive dust as well as ATEX.

Types of assembly

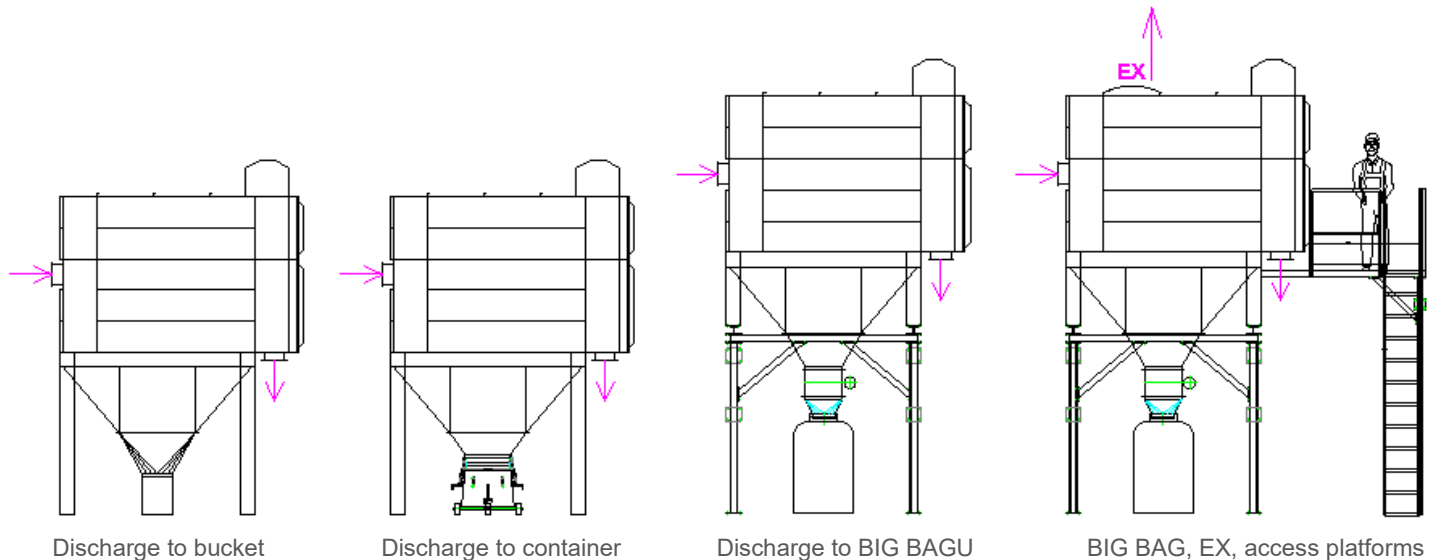

Working conditions for G&G - JET BAG

The filtration device is designed for filtration of air mass with temperature -30 ° C to + 80 ° C in the version without thermal insulation and up to 150 ° C in the version with thermal insulation. The filter is not designed for explosive dust (it can be extended with an option). The suction power is determined by the load factor of the filtering surface for the individual type of dust extracted. The following paragraph lists the most basic applications and the determination of the extraction performance of the G&G - JET BAG filter unit.

Calculation of load on the filtering surface of G&G - JET BAG

The load on the filtering surface is one of the main factors directly influencing the correct functioning of the filtering device for a given application of the filtering device. We strongly recommend that the determination of the appropriate filter area load parameter be determined either by an experienced filter equipment designer or by using the table on the third page of the technical datasheet.

To determine the correct size of the filtration surface, proceed as follows:

Divide the required exhaust rate per minute by the load on the filtering surface (table on page 3) to obtain the optimum filter surface area for your application.

$$\text{m}^3/\text{min} : \text{m}^3/\text{m}^2 \cdot \text{min}^{-1} = \text{size of filtration surface in m}^2$$